

## Model G Installation Information

### ⚠ IMPORTANT ⚠

Please read these instructions carefully to assure correct installation. This equipment must be installed only by a licensed electrician who is experienced with combustion safeguard control systems and understands the functions of interlocking switches, such as gas pressure switches. Prior to being put into operation in conjunction with the combustion safeguard systems, all switches should be tested for proper range setting and proper wiring. Check piping connections and switch house for leaks with a soap bubble test. All exhaust fans and blowers should be inspected and checked for proper rotation prior to starting up.

### Model -G

You are installing one of the finest switches of its type on the market. You will find this switch has many superior features that ensure dependable, accurate, long life operation. This switch is highly sensitive and fully approved. It is UL listed and has FM approval.

### Specifications

**Electrical Ratings:** 10A @ 125 VAC; 10A @ 250 VAC; 1/3 HP, 125 & 250 VAC

**Max. Surge Pressure:** 15 PSI

**Adjustable Operating Pressure:** 1" W.C. to 4 PSI (different ranges)

**Max. Operating Pressure:** 6 PSI (400 mbar) Automatic Reset; 2 PSI (138 mbar) Manual Reset

**Ambient Operating Temperature:** -40°F to 140°F (-40°C to 60 °C)

Field wiring to be rated @ 60°C for maximum 140°F ambient

**Shipping Weight:** .5 lbs. (.227 kg)

#### Options:

NEMA 3S with Kit  
4-Pin DIN Connector  
Neon Lamp Indicator  
Side Mounting

### Dimensions

NOTE: Dimensions are for reference only.

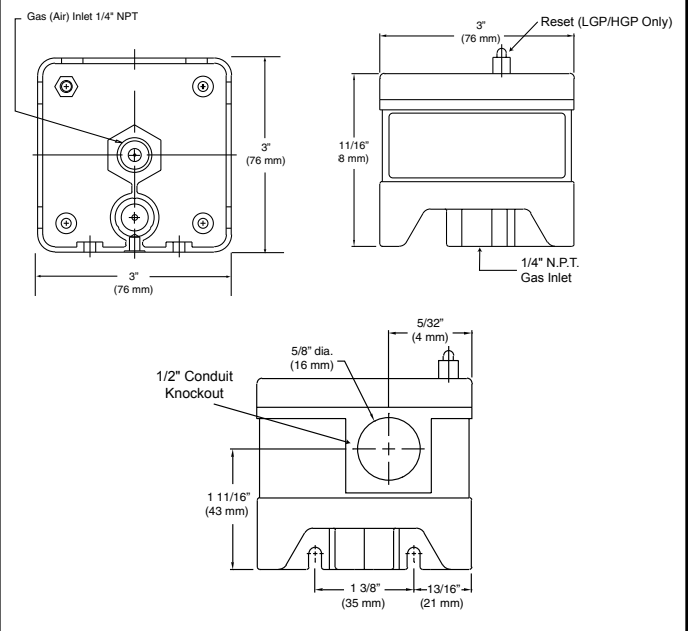

### Low Ranges Available

Model	Part No.	W.C.	mbar
LGP-G	8103116202	1"–20"	3–50
LGP-G	8103116303	5"–30"	12.5–75
LGP-G	8103116407	7"–55"	17.5–137
RLGP-G	8104116102	.5"–4"	1.3–10
RLGP-G	8104116203	1"–20"	2.5–50
RLGP-G	8104116304	5"–30"	12.5–75
Model	Part No.	PSI	Bar
RLGP-G	8104118005	1–4	.07–.28

### High Ranges Available

Model	Part No.	W.C.	mbar
HGP-G	8101111202	2"–20"	5–50
HGP-G	8101111303	8"–35"	20–87
HGP-G	8101111407	10"–60"	25–150
RHGP-G	8102111102	.8"–4"	2–10
RHGP-G	8102111203	2"–20"	5–50
RHGP-G	8102111304	5"–35"	12.5–87
Model	Part No.	PSI	Bar
RHGP-G	8102113005	1–4	.07–.28

## Model G Installation Information

### Mounting

All switches can be mounted in either horizontal or vertical position. Switches should be reasonably level but do not required accurate leveling.

Single gas switch models have a 1/4" NPT (female) gas inlet on the standard base.

Piping can be either standard black pipe or aluminum tubing.

All switches can be supported by the inlet pipe, but optional mounting brackets and bases are available (see Figures 1 thru 5 below).

Switches have been factory calibrated and tested for leaks. However, it is recommended that switch, gas pipe inlets and connections be soap bubble tested for leaks after installation.

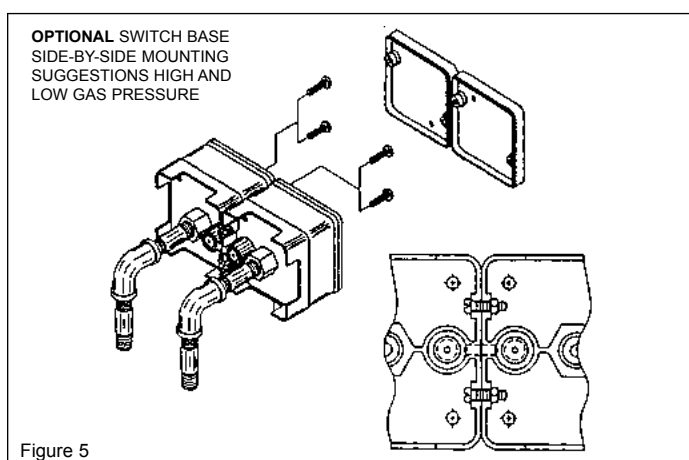
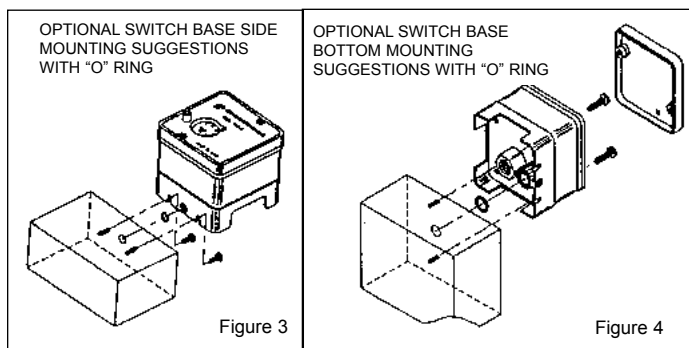
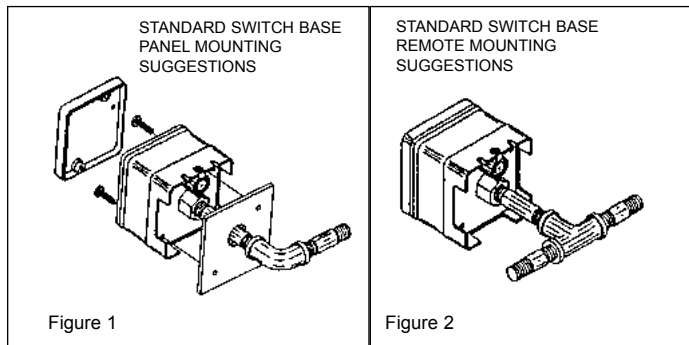

### Operation

#### Low Gas Pressure Models

Low gas pressure switches break the electrical circuit on pressure drop at the point when gas pressure becomes lower than the indicated set pressure.

Before the manual reset button can be properly latched, gas pressure in the chamber must be higher than the indicated setting. The position of the yellow ring on the reset button shows whether the reset button is on or off. If the yellow ring on the button is below the cover, the unit is on (not latched). If the yellow ring is above the cover, the unit is off (latched). The yellow ring must be below the cover after latching to be properly set.

#### High Gas Pressure Models

High gas pressure switches break the electrical circuit when pressure rises above the indicated preset pressure. The yellow ring will be below the cover, indicating that the switch is on, when the gas pressure in the switch chamber is below the indicated high setting. When the yellow ring on the reset button is above the cover, it indicates the switch is in the off position, and gas pressure is above the indicated setting.

#### Range Adjustment - All Models

To adjust gas pressure cut-off setting, remove the cover. Turn the range scale adjustable knob clockwise to increase pressure setting, counterclockwise to decrease pressure setting. Install cover and tighten the two cover screws to prevent tampering.

## Model G Installation Information

### LOW PRESSURE

When pressure decreases below setpoint  
NO opens, NC closes

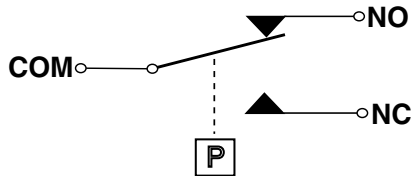
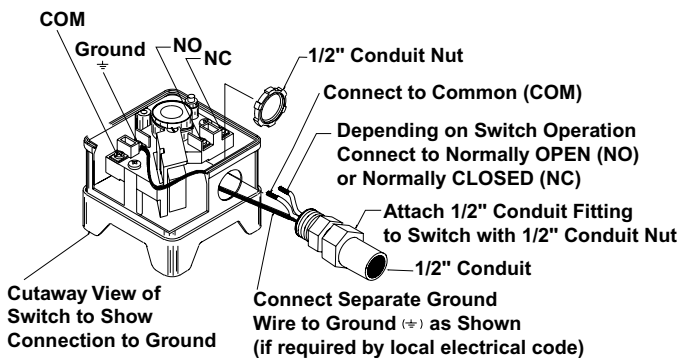
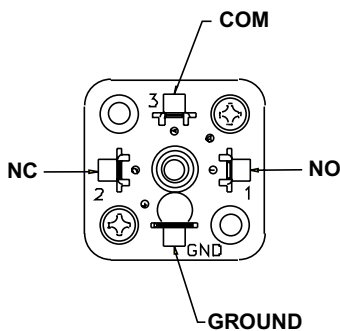

Diagram Shows Pressure Being Applied To Switch

### CONDUIT CONNECTIONS



### DIN CONNECTOR WIRING



### HIGH PRESSURE

When pressure increases above setpoint  
NO closes, NC opens

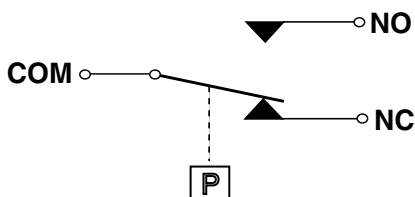

Diagram Shows Pressure Being Applied To Switch

## Warranty

1. Crossroads Industrial Services products are guaranteed to be free from mechanical and electrical defects for a period of one year from date of shipment under normal use and service provided installation is made in accordance with manufacturers' recommendations.
2. Parts deemed defective shall be repaired or replaced at manufacturers option and at manufacturers expense but shall not include foreign or federal excise taxes, state or municipal sale or use taxes, all such taxes not limited to the foregoing being responsibility of the purchaser.
3. No charge for travel and/or mileage will be allowed to purchaser.
4. Crossroads Industrial Services reserves the right to make changes in design or make any improvements on any products. The right is always reserved to modify our equipment because of new technology, underwriter's requirements and/or government regulations.
5. The following are not covered under warranty:
  - a. Failure from neglect, abuse, careless handling and mis-application of unit.
  - b. Failure to observe guidelines for installation or improper voltage hook-up.
  - c. Failure caused by improper maintenance.
  - d. Unless specifically allowed by Crossroads Industrial Services, no other charges may be included under warranty.

**Limitation of Liability:** If it is understood and agreed that seller's liability whether in contract, in tort, under any warranty, in negligence or otherwise, shall not exceed the return of the amount of the purchase price paid by purchaser and under no circumstances shall seller be liable for special, indirect or consequential damages. The price stated for the equipment is a consideration in limiting seller's liability. No action, regardless of form, arising out of the transactions may be brought by purchaser more than one year after the cause of action has accrued.



---

*a division of Crossroads Industrial Services*  
8302 East 33<sup>rd</sup> Street, Indianapolis, IN 46226  
p/ 317.899.7392 • w/ [crossroadsindustrialservices.com](http://crossroadsindustrialservices.com)  
e/ [customersupport@crossroadsindustrialservices.com](mailto:customersupport@crossroadsindustrialservices.com)