

## Model A Installation Information

### ⚠ IMPORTANT ⚠

Please read these instructions carefully to assure correct installation. This equipment must be installed only by a licensed electrician who is experienced with combustion safeguard control systems and understands the functions of interlocking switches, such as gas pressure switches. Prior to being put into operation in conjunction with the combustion safeguard systems, all switches should be tested for proper range setting and proper wiring. Check piping connections and switch house for leaks with a soap bubble test. All exhaust fans and blowers should be inspected and checked for proper rotation prior to starting up.

### Model A Switches

You are installing one of the finest switches of its type on the market. The Model A is adjustable within its range as shown on the range scale located on the front of the unit. The latch position in the reset models and the level indicator position in the recycle models show whether the switch is on or off. It is UL listed and has FM approval.

### Specifications

**Electrical Ratings:** 10A, 1/8 HP @ 125 VAC; 5A, 1/4 HP @ 250 VAC; Pilot Duty, 125 VA @ 125-250 VAC

**Max. Surge Pressure:** 10 PSI

**Max. Ambient Operating Temperature:** 140°F (60°C)

**Min. Ambient Operating Temperature:** -40°F (-40°C)

**Shipping Weight:** HGP-A, LGP-A, RHGP-A, RLGP-A: 2 lbs. (.9 kg)

HLGP-A, RHLGP-A: 4 lbs. (1.8 kg)

#### Options:

Panel Mount

Dust Proof

### Dimensions

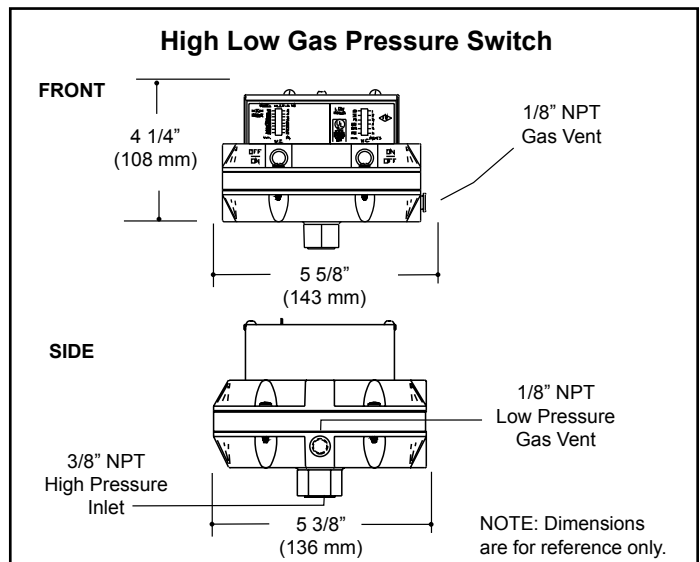
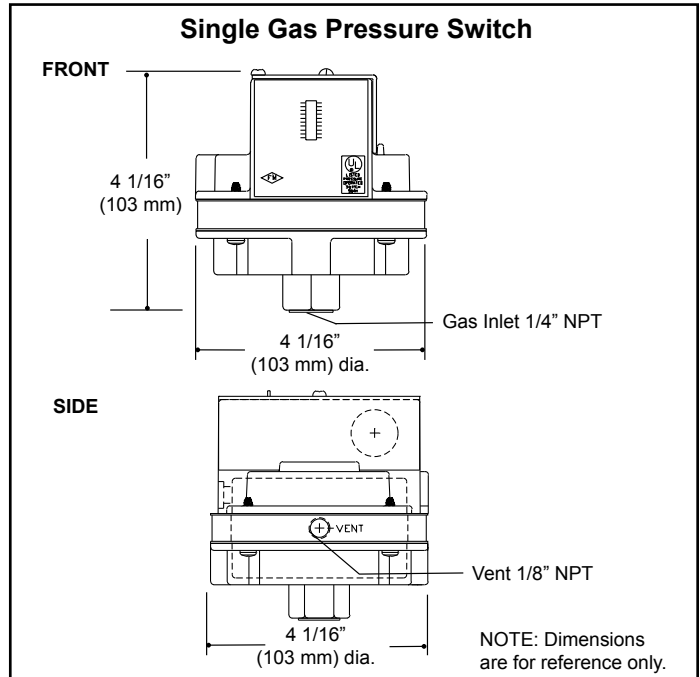

### Range Available

High Gas Pressure		Low Gas Pressure	
2 - 16" W.C.	50-400 mm	1-6" W.C.	25-150 mm
5 - 28" W.C.	125-700 mm	1-35" W.C.	25-875 mm
10 - 50" W.C.	250-1250 mm	2-14" W.C.	50-350 mm
		2-20" W.C.	50-500 mm
		6-24" W.C.	150-600 mm
		10-50" W.C.	250-1250 mm

## Model A Installation Information

### Electrical Wiring-Combination Models

**Reset HLGP-A**

**Model: HLGP-A**  
**Duty:** High Low Gas Reset Switch  
**Elec. Rating:** 10A, 1/8 HP, 125 VAC  
 5A, 1/4 HP, 250 VAC  
**Pilot Duty:** 125 VA, 125-250 VAC

High Gas

By Others

Reset lever will latch when gas pressure is *below* setting

Indicator On

Indicator Off

Reset lever will latch when gas pressure is *above* setting

By Others

Low Gas

Field wiring to be rated @75°C for max 120°F Ambient  
 Field wiring to be rated @90°C for max 140°F Ambient  
 Max Surge Pressure: 10 PSIG

**Reset RHLGP-A**

**Model: RHLGP-A**  
**Duty:** High Low Gas Reset Switch  
**Elec. Rating:** 10A, 1/8 HP, 125 VAC  
 5A, 1/4 HP, 250 VAC  
**Pilot Duty:** 125 VA, 125-250 VAC

High Gas

By Others

Contacts C & NC break when pressure rises *above* setting

Indicator On

Indicator Off

Contacts C & NO make when pressure rises *above* setting

By Others

Low Gas

Field wiring to be rated @75°C for max 120°F Ambient  
 Field wiring to be rated @90°C for max 140°F Ambient  
 Max Surge Pressure: 10 PSIG

### Electrical Wiring-Single Models

**Reset HGP-A**

**Model: HGP-A**  
**Duty:** High Gas Reset Switch  
**Elec. Rating:** 10A, 1/8 HP, 125 VAC  
 5A, 1/4 HP, 250 VAC  
**Pilot Duty:** 125 VA, 125-250 VAC

Reset HGP-A

NC

C

By Others

Reset lever will latch when gas pressure is below setting contact C & NC make

Indicator On

Indicator Off

Field wiring to be rated @75°C for max 120°F Ambient  
 Field wiring to be rated @90°C for max 140°F Ambient  
 Max Surge Pressure: 10 PSIG

**Reset LGP-A**

**Model: LGP-A**  
**Duty:** Low Gas Reset Switch  
**Elec. Rating:** 10A, 1/8 HP, 125 VAC  
 5A, 1/4 HP, 250 VAC  
**Pilot Duty:** 125 VA, 125-250 VAC

Reset LGP-A

NC

C

By Others

Reset lever will latch when gas pressure is above setting contact C & NO make

Indicator On

Indicator Off

Field wiring to be rated @75°C for max 120°F Ambient  
 Field wiring to be rated @90°C for max 140°F Ambient  
 Max Surge Pressure: 10 PSIG

**Recycle RHGP-A**

**Model: RHGP-A**  
**Duty:** High Gas Recycle Switch  
**Elec. Rating:** 10A, 1/8 HP, 125 VAC  
 5A, 1/4 HP, 250 VAC  
**Pilot Duty:** 125 VA, 125-250 VAC

Recycle RHGP-A

NC

C

By Others

Contacts C & NC break when pressure rises above setting

Indicator On

Indicator Off

Field wiring to be rated @75°C for max 120°F Ambient  
 Field wiring to be rated @90°C for max 140°F Ambient  
 Max Surge Pressure: 10 PSIG

**Recycle RLGP-A**

**Model: RLGP-H**  
**Duty:** Low Gas Recycle Switch  
**Elec. Rating:** 10A, 1/8 HP, 125 VAC  
 5A, 1/4 HP, 250 VAC  
**Pilot Duty:** 125 VA, 125-250 VAC

Recycle RLGP-A

NC

C

By Others

Contacts C & NO make when pressure rises above setting

Indicator On

Indicator Off

Field wiring to be rated @75°C for max 120°F Ambient  
 Field wiring to be rated @90°C for max 140°F Ambient  
 Max Surge Pressure: 10 PSIG

## Model A Installation Information

### Operation

**Low Gas Pressure:** Low gas pressure switches break the electrical circuit on pressure drop at the point when gas pressure becomes lower than the indicated set pressure.

Before the manual reset latch can be properly latched, gas pressure in the chamber must be higher than the indicated setting. The position of the reset latch on the top cover of the switch shows whether reset latch is in the on or off position. Reset latch must be in "on" position after latching to be properly set.

**High Gas Pressure:** High gas pressure switches break the electrical circuit when pressure rises above the indicated preset pressure. The reset latch should be latched in the "on" position if the gas pressure in the switch chamber is below the indicated high setting.

**Recycle Models:** High and Low Gas Pressure

Recycle models operate automatically and do not need to be reset. Otherwise they are constructed, adjusted, and operate in the same manner as the reset models.

**Combination Models:** The combination unit contains one high pressure unit and one low pressure unit, in the ranges you select. They may be either reset or recycle type. Each unit has an on/off indicator and its own range scale indicator.

### Mounting

All gas pressure switches must be mounted in a horizontal position with the inlet stem down. Switches should be reasonably level but do not require accurate leveling.

Single gas switch models have a 1/4" NPT gas inlet.

Double combination Hi-Lo switches have a 3/8" NPT for high pressure inlet and a 1/8" NPT for low pressure inlet.

Gas vent outlets are 1/8" NPT on all models.

Piping can be either standard black pipe or aluminum tubing.

All switches can be supported by the inlet pipe, but optional mounting brackets are available if needed.

All switches have been factory-calibrated and tested for leaks. However, it is recommended that after the installation is completed, switch, gas pipe inlets, and connections be tested for leaks with a soap bubble test.

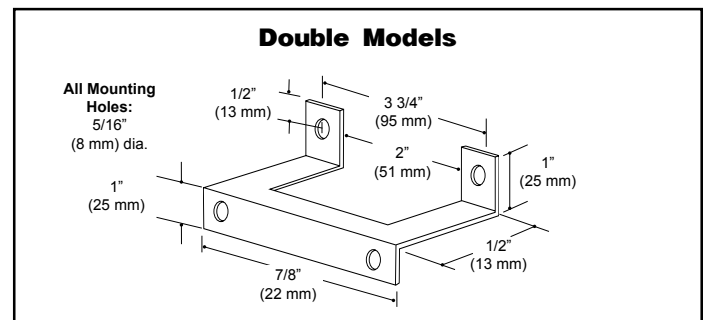
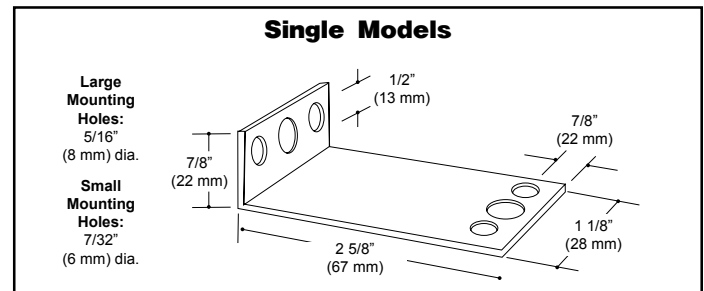

## Model A Installation Information

### Warranty

1. Crossroads Industrial Services products are guaranteed to be free from mechanical and electrical defects for a period of one year from date of shipment under normal use and service provided installation is made in accordance with manufacturers' recommendations.
2. Parts deemed defective shall be repaired or replaced at manufacturers option and at manufacturers expense but shall not include foreign or federal excise taxes, state or municipal sale or use taxes, all such taxes not limited to the foregoing being responsibility of the purchaser.
3. No charge for travel and/or mileage will be allowed to purchaser.
4. Crossroads Industrial Services reserves the right to make changes in design or make any improvements on any products. The right is always reserved to modify our equipment because of new technology, underwriter's requirements and/or government regulations.
5. The following are not covered under warranty:
  - a. Failure from neglect, abuse, careless handling and mis-application of unit.
  - b. Failure to observe guidelines for installation or improper voltage hook-up.
  - c. Failure caused by improper maintenance.
  - d. Unless specifically allowed by Crossroads Industrial Services, no other charges may be included under warranty.

Limitation of Liability: If it is understood and agreed that seller's liability whether in contract, in tort, under any warranty, in negligence or otherwise, shall not exceed the return of the amount of the purchase price paid by purchaser and under no circumstances shall seller be liable for special, indirect or consequential damages. The price stated for the equipment is a consideration in limiting seller's liability. No action, regardless of form, arising out of the transactions may be brought by purchaser more than one year after the cause of action has accrued.



---

*a division of Crossroads Industrial Services*  
8302 East 33<sup>rd</sup> Street, Indianapolis, IN 46226  
p/ 317.899.7392 • w/ crossroadsindustrialservices.com  
e/ customersupport@crossroadsindustrialservices.com