

Versa Plus Gas Pressure Switches Installation Information

⚠ IMPORTANT ⚠

Please read these instructions carefully to assure correct installation. This equipment must be installed only by a licensed electrician who is experienced with combustion safeguard control systems and understands the functions of interlocking switches, such as gas pressure switches. Prior to being put into operation in conjunction with the combustion safeguard systems, all switches should be tested for proper range setting and proper wiring. Check piping connections and switch house for leaks with a soap bubble test. All exhaust fans and blowers should be inspected and checked for proper rotation prior to starting up.

Versa Plus Gas Pressure Switches

Versa Plus Gas Pressure Switches by Crossroads Industrial Services monitor gas pressure and break the electrical control circuit when pressure drops below or rises above the desired setpoint. The gas pressure settings are adjustable and available in manual or automatic reset operation.

These switches are sturdy and constructed with a durable plastic electrical enclosure and a die-cast aluminum inlet base.

Specifications

Electrical Ratings: 6A @ 120 VAC, 6A @ 240 VAC, 1/8 HP 120 & 240 VAC

Adjustable Operating Pressure: 1.2 to 150 mbar
0.5" W.C. to 60" W.C. (different ranges)

NOTE: To avoid initial line fill pressure spikes, unit should be placed downstream of the regulator.

Max. Surge Pressure: 7 PSI (482 mbar)

Ambient Operating Temperature: 5°F to 180°F
(-15°C to 82°C)

Field wiring to be rated @ 90°C (194°F) for maximum ambient

Shipping Weight: 0.5 lbs. (.227 kg)

Options:

4-Pin DIN Connector
Neon Lamp Indicator
Side Mounting

Dimensions

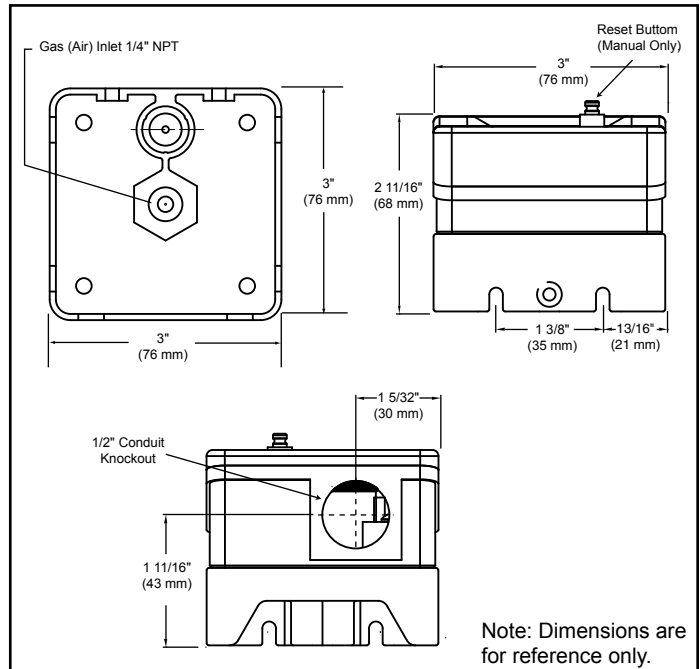

Ranges Available

Low Ranges			
Model	Part No.	W.C.	mbar
<i>Automatic Reset</i>			
FGA-L010	8261001010	0.5"-4"	1.2-10
FGA-L050	8261002050	1"-20"	2.5-50
FGA-L110	8261003110	5"-44"	12-110
<i>Manual Reset</i>			
FGM-L 010	8271001010	0.5"-4"	1.2-10
FGM-L 050	8271002050	1"-20"	2.5-50
FGM-L 075	8271003075	5"-30"	12-75
FGM-L 136	8271004136	7"-55"	17-136

High Ranges			
Model	Part No.	W.C.	mbar
<i>Automatic Reset</i>			
FGA-H010	8261005010	0.8"-4"	2-10
FGA-H050	8261006050	2"-20"	5-50
FGA-H087	8261007087	5"-35"	12-87
<i>Manual Reset</i>			
FGM-H 050	8271005050	2"-20"	5-50
FGM-H 087	8271006087	8"-35"	20-87
FGM-H 150	8271007150	10"-60"	25-150

Versa Plus Gas Pressure Switches Installation Information

Mounting

All switches can be mounted in either horizontal or vertical position. Switches should be reasonably level but do not require accurate leveling.

Single gas switch models have a 1/4" NPT (female) gas inlet on the standard base.

Piping can either be standard black pipe or aluminum tubing.

All switches can be support by the inlet pipe, but optional mounting brackets and bases are available (see Figures 1 through 5).

Switches have been factory calibrated and tested for leaks. However, it is recommended that switch, gas pipe inlets, and connections be soap bubble tested for leaks after installation.

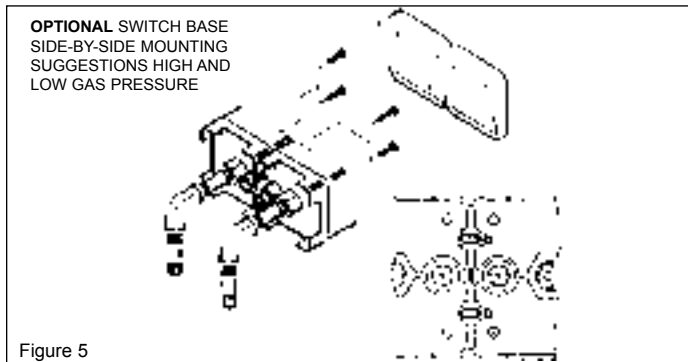
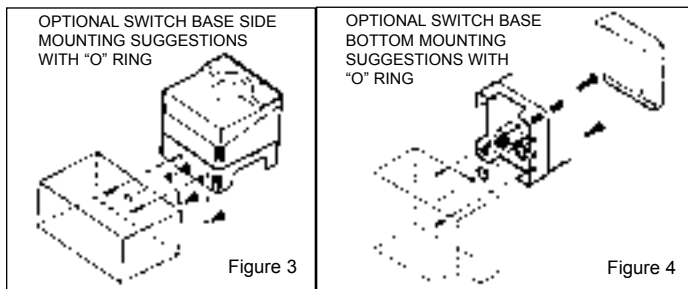
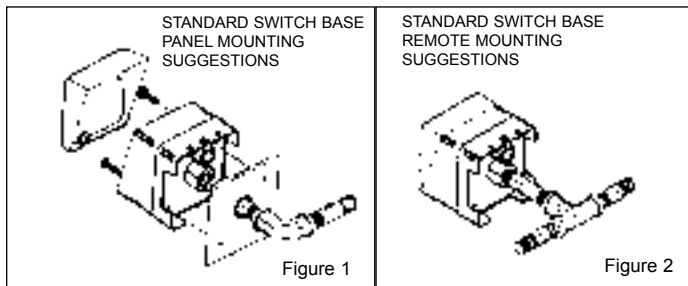

Operation

LOW GAS PRESSURE MODELS

Low gas pressure switches break the electrical circuit on pressure drop at the point when gas pressure becomes lower than the indicated set pressure.

In order to reset the switch, the gas pressure in the chamber must be higher than the indicated setting. For manual reset switches, the reset button must also then be pressed.

HIGH GAS PRESSURE MODELS

High gas pressure switches break the electrical circuit when pressure rises above the indicated preset pressure.

In order to reset the switch, the gas pressure in the chamber must be lower than the indicated setting. For manual reset switches, the reset button must also then be pressed.

RANGE ADJUSTMENT (ALL MODELS)

To adjust gas pressure cutoff setting, remove the cover. Turn the range scale adjustable knob (Figure 6) clockwise to increase pressure setting, counterclockwise to decrease pressure setting. Install cover and tighten the two cover screws to prevent tampering.

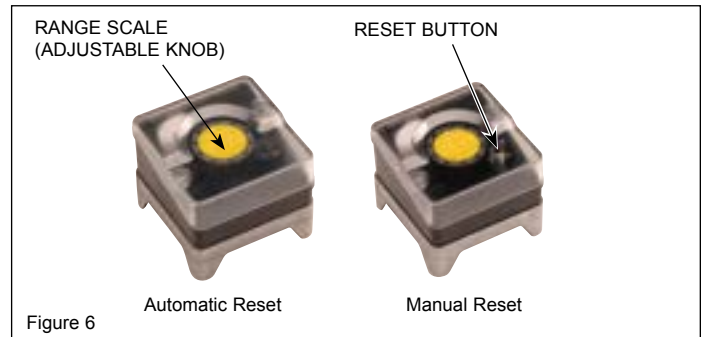

Versa Plus Gas Pressure Switches Installation Information

High Pressure

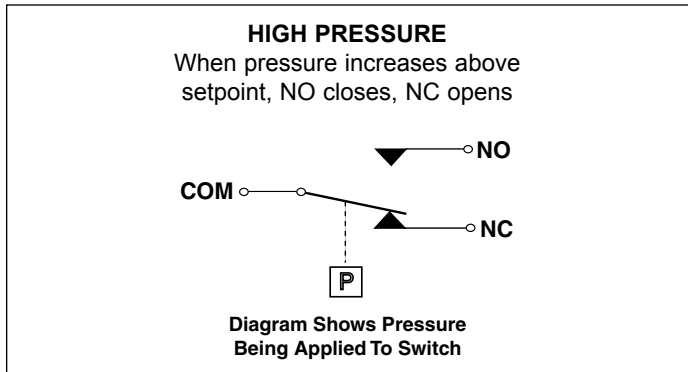

Low Pressure

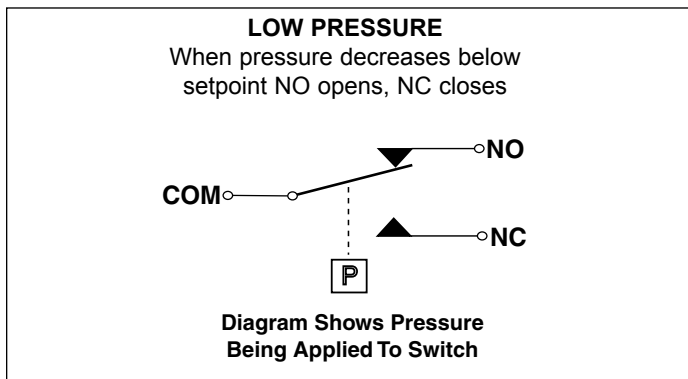

DIN Connector Wiring

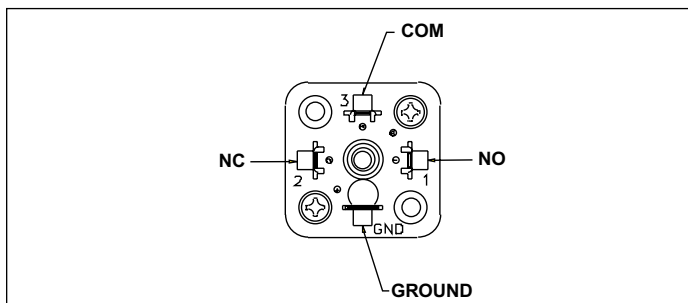

Conduit Connections

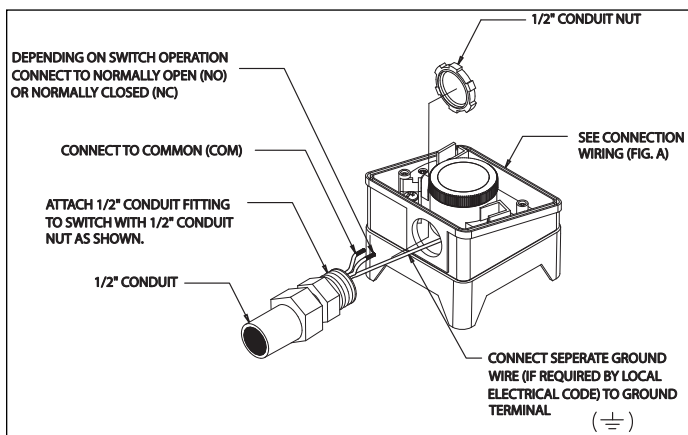

Warranty

1. Crossroads Industrial Services products are guaranteed to be free from mechanical and electrical defects for a period of one year from date of shipment under normal use and service provided installation is made in accordance with manufacturers' recommendations.
2. Parts deemed defective shall be repaired or replaced at manufacturers option and at manufacturers expense but shall not include foreign or federal excise taxes, state or municipal sale or use taxes, all such taxes not limited to the foregoing being responsibility of the purchaser.
3. No charge for travel and/or mileage will be allowed to purchaser.
4. Crossroads Industrial Services reserves the right to make changes in design or make any improvements on any products. The right is always reserved to modify our equipment because of new technology, underwriter's requirements and/or government regulations.
5. The following are not covered under warranty:
 - a. Failure from neglect, abuse, careless handling and mis-application of unit.
 - b. Failure to observe guidelines for installation or improper voltage hook-up.
 - c. Failure caused by improper maintenance.
 - d. Unless specifically allowed by Crossroads Industrial Services, no other charges may be included under warranty.

Limitation of Liability: If it is understood and agreed that seller's liability whether in contract, in tort, under any warranty, in negligence or otherwise, shall not exceed the return of the amount of the purchase price paid by purchaser and under no circumstances shall seller be liable for special, indirect or consequential damages. The price stated for the equipment is a consideration in limiting seller's liability. No action, regardless of form, arising out of the transactions may be brought by purchaser more than one year after the cause of action has accrued.

