

Versa Pro Air Installation Information

⚠ IMPORTANT ⚠

Please read these instructions carefully to assure correct installation. This equipment must be installed only by a licensed electrician who is experienced with combustion safeguard control systems and understands the functions of interlocking switches, such as gas pressure switches. Prior to being put into operation in conjunction with the combustion safeguard systems, all switches should be tested for proper range setting and proper wiring. Check piping connections and switch house for leaks with a soap bubble test. All exhaust fans and blowers should be inspected and checked for proper rotation prior to starting up.

Specifications

Maximum Operating Pressure: 690 mbar (69 kPa)

Max Surge Pressure: 1 bar

Temperature:

Ambient: -15°C to 60°C

Medium: -15°C to 60°C

Storage: -30°C to 80°C

Electrical Ratings:

6A @ 250 VAC

Protection: IP 54 approved to IEC 529 (EC60529)

Electrical Connection: 3-pin connector for line sockets as per DIN - EN 175 301 - 803 (without ground protection).

Connection: 1/4-19 BSP Thread

Shipping Weight: 0.25 lbs. (.11 kg)

Options: Contact Antunes Controls

Switching Function

As pressure rises:

1 NC opens, 2 NO closes

As pressure falls:

1 NC closes, 2 NO opens

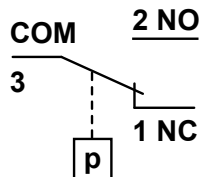

Dimensions

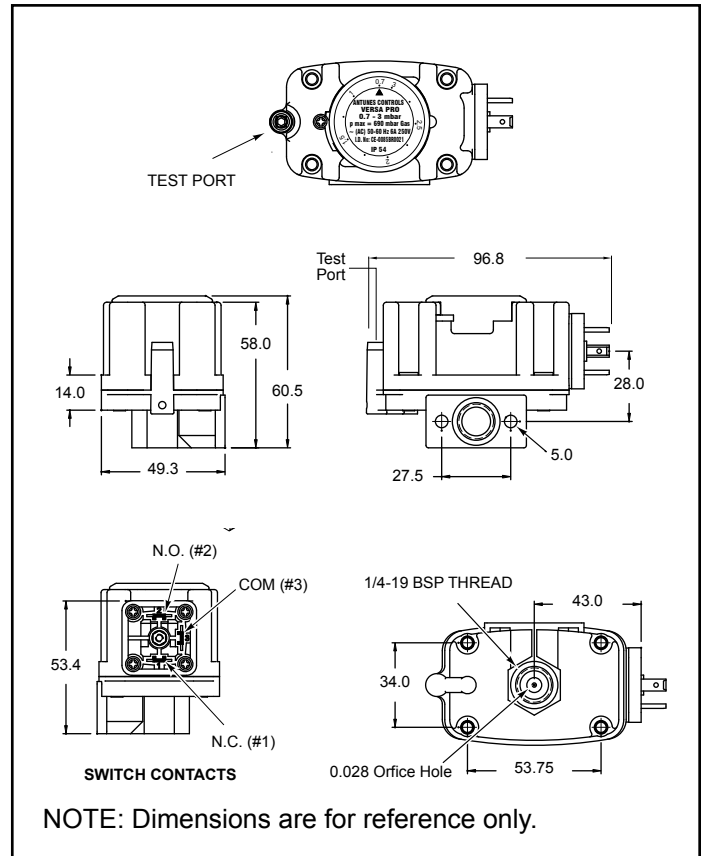

Technical Data

Base Type	Version	Antunes Order No.	Range	Switch Differential
Center Mount	FCA 003	8191031003	0.7 - 3.0 mbar	≤ 0.7
	FCA 010	8191032010	2.0 - 10.0 mbar	≤ 1.0

Versa Pro Air Installation Instructions

Warranty

1. Crossroads Industrial Services products are guaranteed to be free from mechanical and electrical defects for a period of one year from date of shipment under normal use and service provided installation is made in accordance with manufacturers' recommendations.
2. Parts deemed defective shall be repaired or replaced at manufacturers option and at manufacturers expense but shall not include foreign or federal excise taxes, state or municipal sale or use taxes, all such taxes not limited to the foregoing being responsibility of the purchaser.
3. No charge for travel and/or mileage will be allowed to purchaser.
4. Crossroads Industrial Services reserves the right to make changes in design or make any improvements on any products. The right is always reserved to modify our equipment because of new technology, underwriter's requirements and/or government regulations.
5. The following are not covered under warranty:
 - a. Failure from neglect, abuse, careless handling and mis-application of unit.
 - b. Failure to observe guidelines for installation or improper voltage hook-up.
 - c. Failure caused by improper maintenance.
 - d. Unless specifically allowed by Crossroads Industrial Services, no other charges may be included under warranty.

Limitation of Liability: If it is understood and agreed that seller's liability whether in contract, in tort, under any warranty, in negligence or otherwise, shall not exceed the return of the amount of the purchase price paid by purchaser and under no circumstances shall seller be liable for special, indirect or consequential damages. The price stated for the equipment is a consideration in limiting seller's liability. No action, regardless of form, arising out of the transactions may be brought by purchaser more than one year after the cause of action has accrued.



Industrial Services, 8302 East 33rd Street, Indianapolis, IN 46226

p/ 317.897.7320 | crossroadsindustrialservices.com